

UNMATCHED PERFORMANCE AND DURABILITY!



OUR ULTIMATE RANGE
OF CHEMICAL COMPATIBILITY

SVP150

DEPENDABLE & EFFICIENT



THE NEW LIP SEAL STAINLESS
STEEL VANE PUMP BY PARAGON,
OFFERS A WIDER RANGE OF
PUMPING SOLUTIONS TO THE
TANK TRUCK INDUSTRY!

WWW.PARAGONDIRECT.COM

3" NPT

**LIP
SEAL**

S.S.

**150
GPM**

**HYD.
DRIVE**



PARAGON

NEW LIP SEAL TECHNOLOGY

PERFORMANCE DATA

PUMP MODEL - SVP150					
RATED PUMP SPEED	VISCOSITY	GPM	L/MIN	BHP	KW
640 RPM	1000 SSU	120	454	5.0	3.7
520 RPM	5000 SSU	98	371	3.8	2.8

MAXIMUM OPERATING LIMITS

Pump Model	Nominal Flowrate		Pump Speed	Viscosity		Differential Pressure		Working Pressure	
	gpm	L/min.	rpm	ssu	cP	psi	bar	psi	bar
	SVP150	157	594	780	20,000	4,250	80	8.6	175

WEIGHT AND DIMENSIONS

Model		A	B	C	D	E	F	G	H	I	Port Size	Approx. Weight
SVP150 (3" port)	in.	12 1/2"	14"	13 1/2"	14 3/4"	17 1/4"	1/4"	1 1/8"	5 1/2"	3"	3"	95 lbs.
	mm	317.5	355.6	342.9	374.7	28.6	6.4	28.6	139.7	76.2	76.2	43.1 kg

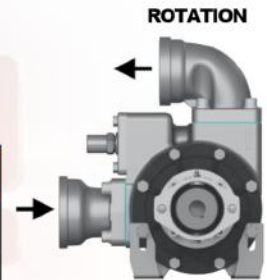
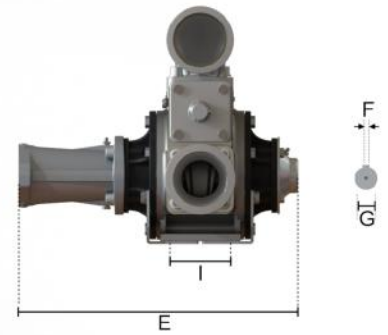
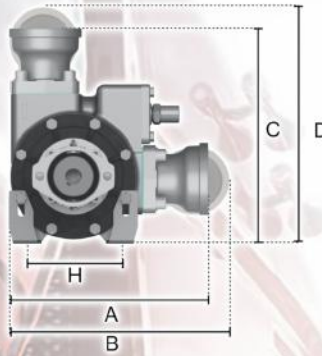

LEFT HAND (STANDARD*)

* RIGHT HAND ROTATION OPTIONAL

S 150 S E V R X -01

Product Pump Type:
Stainless Steel Vane Pump

Max Flow Rate:
150 GPM

Inlet:

- X - None
- S - Straight Port SS
- E - Elbow 3" Port SS

Outlet:

- S - Straight Port SS
- E - Elbow 3" Port SS

Hydraulic Motor:
-XX - No Hydraulic Motor
-01 - 4.9 cu" (Standard)
-02 - 6.2 cu"

Mounting Bracket:

- X - No Bracket
- 2 - Standard Bracket
- 3 - Bracket w/SCV
- 4 - Bracket w/DCV
- 5 - Dual Spool, one AUX
- 6 - Dual Spool, two AUX

Rotation:

- L - Left Hand (Standard)

Seals:

- B - Mechanical Seal - Buna
- V - Mechanical Seal - Viton
- K - Mechanical Seal - PTFE/Chemraz®
- L - Double Lip Seal - PTFE/Chemraz®

Model Code



PARAGON TANK TRUCK EQUIPMENT

2111 US HIGHWAY 411 NE
CARTERSVILLE, GA, 30121-5123
TEL: +1 (800) 471-8769
EMAIL: INFO@PARAGONDIRECT.COM